



RUB RAIL

STEM TO STERN

Rub Rail products recognized for durability and precision engineering to perfectly match the contours of your boat.





PROFESSIONAL FLEX FOR ULTIMATE PROTECTION

Introducing the future of hull protection with the new family of SuproFlex Rub Rail – lightweight, ultra-flexible profiles to save you time and money while providing a seamless precision fit. The innovative SuproFlex series is co-extruded vinyl that provides two levels of hardness – ensuring enhanced protection from impact. SuproFlex Rub Rail requires minimal heating – reducing installation time and manpower. Additionally, SuproFlex Rub Rail requires no pre-forming and easily molds to most hull shapes. This new rub rail is available in a variety of sizes and colors, and pairs with TACO’s patented Flex Chrome Insert, which can also be customized to any builder’s color preference. SuproFlex Rub Rail is ideal for any boat up to 65’. For more information, contact your TACO Representative today and visit our website tacomarine.com.

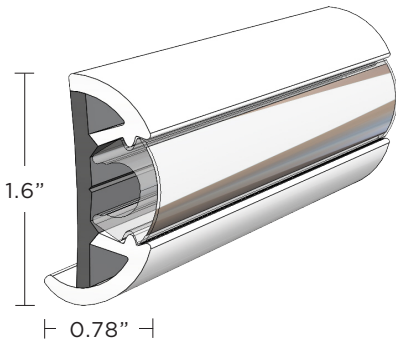

V11-9960

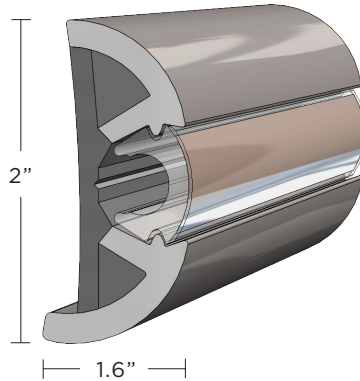

V11-9990

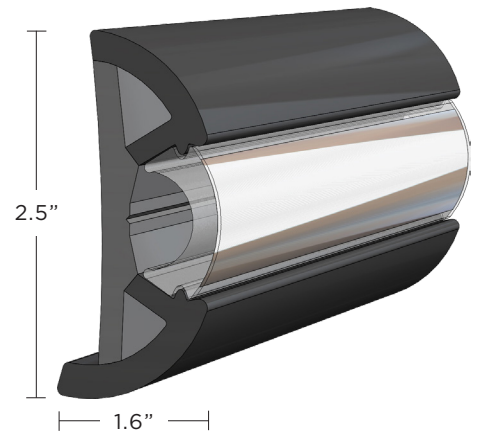

V11-9970

PART NUMBER	DESCRIPTION	COLOR	LENGTH	INSERT*
V11-9960BKA60D	SuproFlex, small, 1.6" X .78"	Black	60'	V12-0307CP / V12-0307BP / V12-0307WP
V11-9960WHA60D	SuproFlex, small, 1.6" X .78"	Arctic White	60'	V12-0307CP / V12-0307BP / V12-0307WP
V11-9960WHC60D	SuproFlex, small, 1.6" X .78"	Frosty White	60'	V12-0307CP / V12-0307BP / V12-0307WP
V11-9990BKA60D	SuproFlex, medium, 2" x 1.2"	Black	60'	V12-0307CP / V12-0307BP / V12-0307WP
V11-9990WHA60D	SuproFlex, medium, 2" x 1.2"	Arctic White	60'	V12-0307CP / V12-0307BP / V12-0307WP
V11-9990WHC60D	SuproFlex, medium, 2" x 1.2"	Frosty White	60'	V12-0307CP / V12-0307BP / V12-0307WP
V11-9990BKA80D	SuproFlex, medium, 2" x 1.2"	Black	80'	V12-0307CP / V12-0307BP / V12-0307WP
V11-9990WHA80D	SuproFlex, medium, 2" x 1.2"	Arctic White	80'	V12-0307CP / V12-0307BP / V12-0307WP
V11-9990WHC80D	SuproFlex, medium, 2" x 1.2"	Frosty White	80'	V12-0307CP / V12-0307BP / V12-0307WP
V11-9970BBK100D	SuproFlex, large, 2.5" x 1.2"	Black	100'	V12-9980CP
V11-9970WHA100D	SuproFlex, large, 2.5" x 1.2"	Arctic White	100'	V12-9980CP
V11-9970WHC100D	SuproFlex, large, 2.5" x 1.2"	Frosty White	100'	V12-9980CP

*Insert sold separately.

All profiles drilled 8" on center.

FOR CUSTOM LENGTHS AND ORDER QUANTITIES, CONTACT YOUR TACO REP TODAY.

RIGID VINYL RUB RAIL



Our Rigid Vinyl Rub Rail provides the ultimate in durability and elegance. A boat has contours that challenge the need for Rub Rail protection – we meet those needs using the highest-quality vinyl components and precision engineering. Choose from a variety of Rigid Vinyl Rub Rail types, including with or without a stainless-steel, vinyl or Flex Chrome insert – designed to withstand the harsh abuse that a boat is subjected to in the marine environment.

2" X 7/8"

V21-9906

- ▶ Solid, rigid PVC cap stock exhibits traditional surface characteristics, appearance and impact properties
- ▶ Continuous coil eliminates butt joints around gunwale, with improved bending characteristics and ability to cold form
- ▶ Stainless steel insert S11-4511*

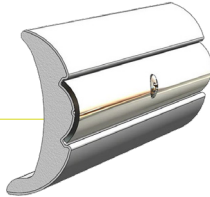

1-1/2" X 7/8"

V21-9501

- ▶ Color and gloss level matched to gel coat, blending rub rail with hull and deck
- ▶ Cuts and drills with standard woodworking tools
- ▶ Either V12-0303 or V12-0307 vinyl insert*

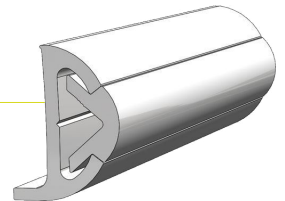

2" X 1"

V21-9502

- ▶ Color and gloss level matched to gel coat, blending rub rail with hull and deck
- ▶ Cuts and drills with standard woodworking tools
- ▶ Stainless steel insert S11-4650*

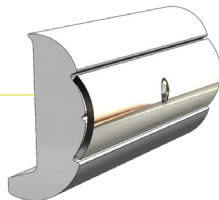

1-7/8" X 1"

V21-9602

- ▶ Color and gloss level matched to gel coat, blending rub rail with hull and deck
- ▶ Cuts and drills with standard woodworking tools
- ▶ Vinyl insert V12-0303*

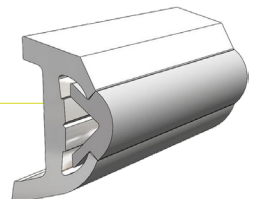

1-5/8" X 5/8"

V21-9659

- ▶ Color and gloss level matched to gel coat, blending rub rail with hull and deck
- ▶ Cuts and drills with standard woodworking tools
- ▶ Stainless steel insert S11-4511*

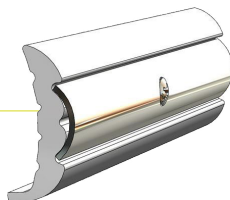

1-5/8" X 3/4"

V21-9811

- ▶ Hard durometer creates rigid-like look
- ▶ Continuous coil allows for one-piece installation without seams
- ▶ Tight radius bending can be made with little or no heating
- ▶ Flex Chrome Insert V12-9809*

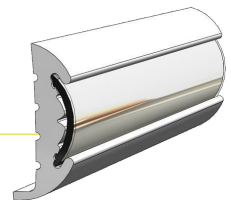

2-1/4" X 7/8"

V21-9790

- ▶ Color and gloss level matched to gel coat, blending rub rail with hull and deck
- ▶ Cuts and drills with standard woodworking tools
- ▶ Stainless steel insert S11-4650*

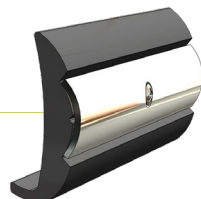

1-3/4" X 3/4"

V21-0457

- ▶ Color and gloss level matched to gel coat, blending rub rail with hull and deck
- ▶ Designed for use without an insert
- ▶ Cuts and drills with standard woodworking tools

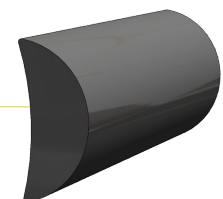

FOR CUSTOM LENGTHS AND ORDER QUANTITIES, CONTACT YOUR TACO REP TODAY. *INSERTS SOLD SEPARATELY

FLEXIBLE VINYL RUB RAIL



Offered in a continuous coil, our Flexible Rub Rail provides a seamless, one-piece, easy-to-bend and stylish solution for all types and sizes of boats. Depending on the application, we offer a range of Flexible Rub Rail profiles that vary from soft to semi-rigid durometers.

2-3/8" X 1-1/2"

V11-0899

- ▶ Tight-radius bending can be made with minimal heating
- ▶ Vinyl insert V12-0005*

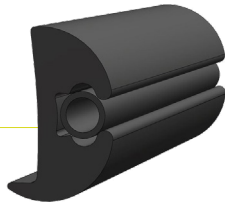

1-7/8" X 1-1/8"

V11-2423

- ▶ Tight-radius bending can be made with minimal heating
- ▶ Vinyl insert V12-0003*

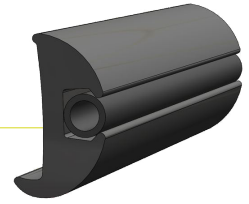

1-1/4" X 1"

V11-3447

- ▶ Tight-radius bending can be made with minimal heating
- ▶ Vinyl insert V12-0003*



2" X 1"

V11-9696

- ▶ Tight-radius bending can be made with minimal heating
- ▶ Stainless Steel insert S11-4511*

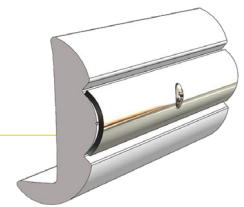

1-5/8" X 1-3/8"

V11-9772

- ▶ Tight-radius bending can be made with minimal heating
- ▶ Vinyl insert V12-0009*

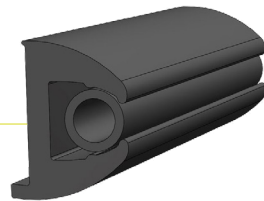

1-5/8" X 5/8"

V11-9798

- ▶ Continuous coil allows for one-piece installation without seams
- ▶ Hard durometer creates rigid-like look
- ▶ Tight-radius bending can be made with little or no heating
- ▶ Stainless Steel insert S11-4511*

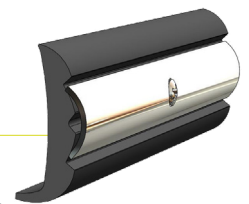

3-3/8" X 1-1/2" DOCK BUMPER

V11-0948

- ▶ Soft durometer absorbs impact and protects dock and boat from damage during docking
- ▶ Continuous coil allows seamless, one-piece installation

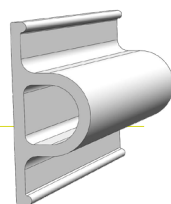

2-1/4" X 1-7/8" DOCK BUMPER

V11-0961

- ▶ Soft durometer absorbs impact and protects dock and boat from damage during docking
- ▶ Continuous coil allows seamless, one-piece installation

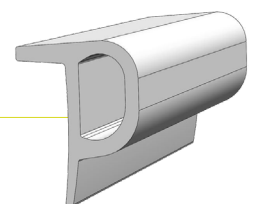

FOR CUSTOM LENGTHS AND ORDER QUANTITIES, CONTACT YOUR TACO REP TODAY. *INSERTS SOLD SEPARATELY

STAINLESS STEEL RUB RAIL

Elegance, durability and impact resistance are the three main reasons why boat builders choose our TACO Stainless Steel Rub Rail. Using types 304 and 316L marine-grade stainless steel with buffed and polished mirror finishes, our Stainless Steel Rub Rail is the best choice for long-term value, corrosion resistance and appearance.

1/2" HOLLOW BACK

S11-4500

- ▶ Stainless Steel Type-304
- ▶ Drilled and countersunk for #6 screws on 6" centers

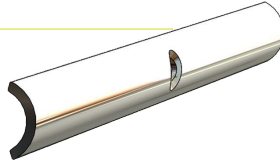

3/4" HOLLOW BACK

S11-4511

- ▶ Stainless Steel Type-304/316L
- ▶ Drilled and countersunk for #8 screws on 6" centers

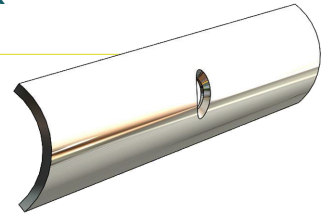

1" HOLLOW BACK

S11-4650

- ▶ Stainless Steel Type-304/316L
- ▶ Drilled and countersunk for #10 screws on 6" centers

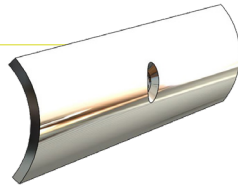

1-1/4" HOLLOW BACK

S11-4670

- ▶ Stainless Steel Type-304
- ▶ Drilled and countersunk for #10 screws on 6" centers

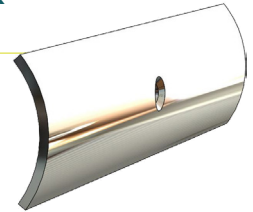

1-1/2" HOLLOW BACK

S11-4690

- ▶ Stainless Steel Type-304
- ▶ Drilled and countersunk for #10 screws on 6" centers

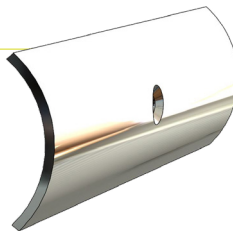

1/2" SOLID BACK

S11-4505

- ▶ Stainless Steel Type-304
- ▶ Drilled and countersunk for #6 screws on 6" centers

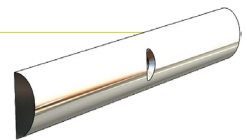

3/4" SOLID BACK

S11-4515

- ▶ Stainless Steel Type-316L
- ▶ Drilled and countersunk for #10 screws on 6" centers

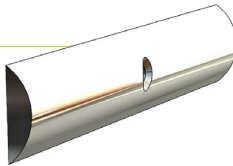

1" SOLID BACK

S11-4655

- ▶ Ideal for larger, heavier boats and yachts
- ▶ Stainless Steel Type-316L
- ▶ Drilled and countersunk for #12 screws on 6" centers

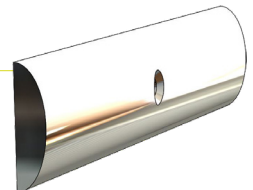

1-1/4" SOLID BACK

S11-4675

- ▶ Ideal for larger, heavier boats and yachts
- ▶ Stainless Steel Type-316L
- ▶ Drilled and countersunk for #12 screws on 6" centers

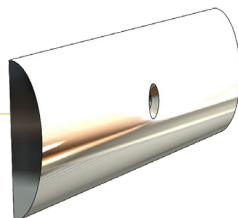

1-1/2" SOLID BACK

S11-4695

- ▶ Ideal for larger, heavier boats and yachts
- ▶ Stainless Steel Type-316L
- ▶ Drilled and countersunk for #12 screws on 6" centers

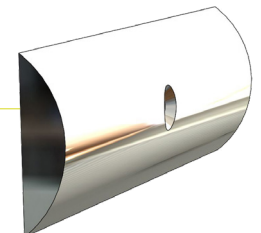

FOR CUSTOM LENGTHS AND ORDER QUANTITIES, CONTACT YOUR TACO REP TODAY.

ALUMINUM RUB RAIL

Using premium marine-grade alloys, our Aluminum Rub Rail profiles are built for strength, performance and appearance – providing boats with an appealing, classic look with a polished, Anodized finish designed to withstand the harshest marine environments. Choose from a variety of Aluminum Rub Rail in solid profiles and profiles with a flexible vinyl insert, which hides fasteners and provides extra cushioning protection.

3/4" X 3/8"

A11-0151

- Designed for use without an insert
- Traditional anodized aluminum edge molding and seam binders
- Drilled and countersunk for #8 screws on 6" centers

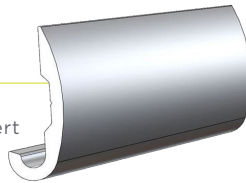

1" X 1/2"

A11-0152

- Designed for use without an insert
- Traditional anodized aluminum edge molding and seam binders
- Drilled and countersunk for #8 screws on 6" centers

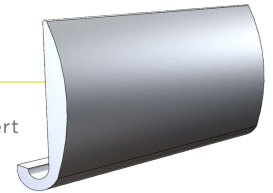

1" X 1/2"

A11-0342

- Ideal for 16' to 24' boats
- Drilled and countersunk for #8 screws on 6" centers
- Vinyl insert V12-0342*

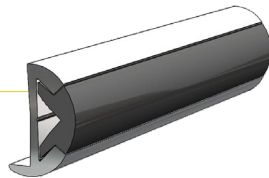

1-3/8" X 7/8"

A12-0303

- Ideal for 16' to 24' boats
- Drilled and countersunk for #10 Screws on 6" centers
- Vinyl insert V12-0303*

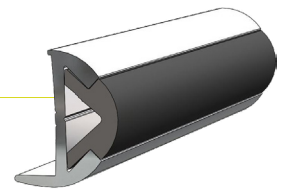

1-3/8" X 1"

A12-0305

- Ideal for 16' to 24' boats
- Drilled and countersunk for #10 Screws on 6" centers
- Vinyl insert V12-0303*

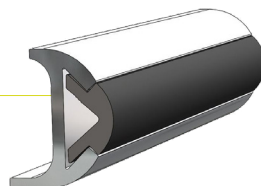

3/4" X 1/4"

A50-0195

- Designed for use without an insert
- Traditional anodized aluminum edge molding and seam binders
- Drilled and countersunk for #5 screws on 6" centers

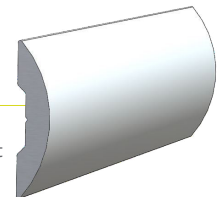

1" X 1/4"

A50-0197

- Designed for use without an insert
- Traditional anodized aluminum edge molding and seam binders
- Drilled and countersunk for #6 screws on 6" centers

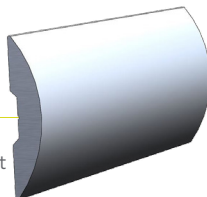

1-1/4" X 1/4"

A50-0199

- Designed for use without an insert
- Traditional anodized aluminum edge molding and seam binders
- Drilled and countersunk for #6 screws on 6" centers

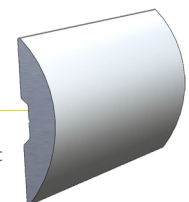

FOR CUSTOM LENGTHS AND ORDER QUANTITIES, CONTACT YOUR TACO REP TODAY. *INSERTS SOLD SEPARATELY

VINYL INSERTS



Accent your Rub Rail with a secure, seamless Vinyl Insert – available in a variety of colors, shapes and sizes for a precision fit. Designed to pair with Rigid, Semi-Rigid, Flexible or Aluminum Rub Rail profiles, our Vinyl Inserts are a secure solution to hide fasteners while also providing a cushion to protect against impact damage.

1/2" TUBE STYLE

V12-0003



1" X 1/2"

V12-0303

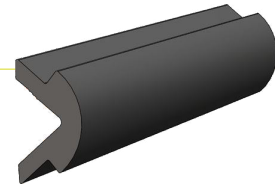

1-1/4" X 1/2"

V12-4144



1" X 1/2"

V12-9787

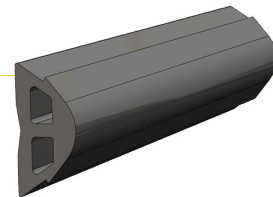

FLEX CHROME INSERTS

Get the look of elegant stainless steel without the price tag. Our Flex Chrome has passed extensive testing for heat/humidity freeze cycle, salt spray, shock and accelerated weathering. It will not corrode, even if penetrated. With a variety of shapes and lengths available, the Flex Chrome Insert comes in one continuous coil for a smooth, clean appearance.

PATENT #US6349662

1-1/8" X 5/8"

V12-9873CP

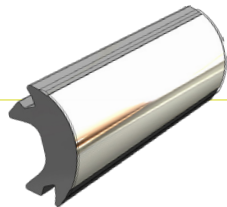

3/4" X 1/2"

V12-0307CP

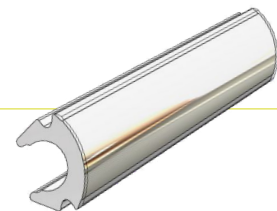

5/8" X 3/8"

V12-1069CP

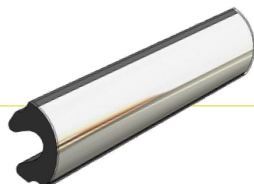

1" X 1-1/4"

V12-9809CP

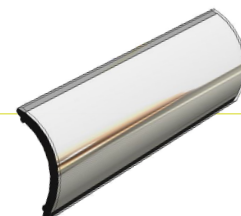

FOR CUSTOM LENGTHS AND ORDER QUANTITIES, CONTACT YOUR TACO REP TODAY.

RUB RAIL ACCESSORIES & MORE

Accessorize your Rub Rail with our premium line of end caps, rub strakes and USCG-approved Rub Rail LED Navigation Lights. Find all these products and more on our website [tacomarine.com](https://www.tacomarine.com).

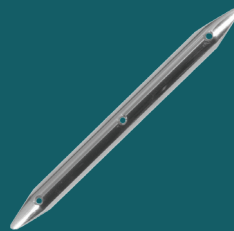
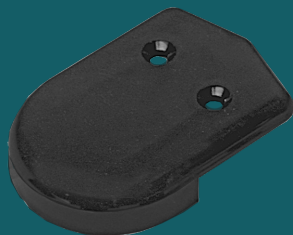
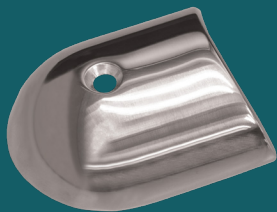
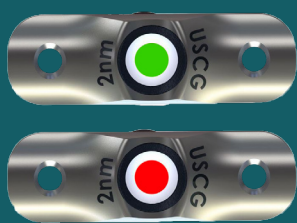

TACO[®]
MARINE

Explore our complete line of
Rub Rail products today.

[TACOMARINE.COM](https://www.tacomarine.com)

[f](#) [@](#) [@tacomarine](#) [@](#) [@taco_marine](#) <#> [#TACORUBRAIL](#)